

# **SKE Radar Level Sensor SK-R800WS**

**Manual Book(Version: 2.1)**



**(SKE) Shaanxi ShengKe Electronic Technology Co., Ltd**

## Catalogue

1. Warranty and service scope of radar .....	3
2. Unpacking inspection and precautions .....	3
2.1 Unpacking inspection .....	4
2.2 Precautions .....	4
3. Storage and transportation .....	4
3.1 Storage conditions .....	4
3.2 Transport the product to the measuring place .....	5
4. Product introduction .....	5
4.1 Product Overview .....	5
4.2 Technical parameters .....	6
4.3 Application .....	6
4.3.1 Measured medium .....	6
4.3.2 Ambient temperature of radar level sensor .....	6
4.3.3 Protection grade .....	7
5. Outline structure of radar level sensor .....	7
5.1 Outline structure diagram .....	7
6. Terminal block of radar level sensor .....	8
7. Wire connection .....	8
8. Modbus (RS485) connection .....	9
9. Description of radar debugging parameters .....	10
9.1 Waveform interface .....	12
9.2 Radar menu .....	12
9.2.1 User menu .....	12
9.2.2 Setting range and definition of basic parameters .....	13
10. Radar installation and commissioning .....	14
10.1 Preparations before installation .....	14
10.2 Selection of radar installation position .....	14
10.3 Software configuration description .....	17
11. Maintenance and repair .....	20
12. Trouble Shooting .....	21

## **1. Warranty and service scope of radar**

The warranty period of the radar level sensor is one year from the date of delivery. This warranty is only limited to the users of the original buyer or the designated dealer, and does not apply to users who use it wrongly for human reasons, transform, neglect or damage it due to accidents and abnormal use.

For the faulty radar level sensor returned within the scope of warranty, free maintenance is provided. To obtain warranty service, please contact the after-sales service department and attach the fault description. With the permission of our company, send the radar sensor to the after-sales service department.

If the radar level sensor has expired the warranty period or it is confirmed that the failure is caused by misuse, modification, negligence, accident and abnormal conditions, the maintenance cost budget will be provided according to the relevant maintenance charge standard, and the maintenance will be carried out after it is approved. After the radar level sensor is repaired, it is sent back to the customer, and the customer needs to pay the maintenance and transportation costs.

## **2. Unpacking inspection and precautions**

## 2. 1 Unpacking inspection

- Instruction manual
- Certificate of conformity
- Packing list
- Radar Level Sensor
- Check the name, model and other contents on the nameplate
- Check whether the radar sensor housing is intact and observe
- Check the random items against the packing list
- Check whether the specifications, models and accessories are correct and complete according to the packing list of the radar level sensor. If there is any problem, please contact the customer service center in time for replacement.

## 2. 2 Precautions

- Please check this manual before installing the radar level sensor.
- Modifications due to product upgrading are subject to change without notice.  
Please refer to the real object.

## 3. Storage and transportation

### 3. 1 Storage conditions

- Temperature:  $-20^{\circ}\text{C} \sim +70^{\circ}\text{C}$
- Use the original packaging

## 3.2 Transport the product to the measuring place

- Use the original packaging to transport the radar sensor to the measuring place.
- Collision, dampness and chemical erosion shall be prevented during transportation and storage.

## 4. Product introduction

### 4.1 Product Overview

77-81 Ghz frequency modulated continuous wave (FMCW) radar products (also known as millimeter wave radar) adopt the millimeter wave band with higher frequency than Ku-band radar. They have important applications in long-range target detection, long-range imaging, multi-spectral imaging in strong smoke and dust environment, and can detect smaller targets than microwave radar and achieve more accurate positioning, with higher resolution and stronger confidentiality.

As a 80GHz band radar used in the field of industrial measurement, high-precision, non-contact level and liquid level measurement has incomparable advantages over other ordinary microwave pulse radars and guided wave radars. With extremely narrow beam and penetration ability, it can better adapt to ultra complex working conditions without weakening the measurement performance.

## 4.2 Technical parameters

<b>Radar Level</b>	Two-wire
<b>Max range</b>	10m、20m、30m、50m
<b>Error</b>	2mm
<b>Migration/Offset</b>	±9.9m
<b>Signal output</b>	4~20mA / Mod-bus / HART
<b>Power supply</b>	Two-wire DC 24V (22V~30V)
<b>Ambient temperature</b>	-20℃~+70℃
<b>Ambient humidity</b>	(0%~95%) RH
<b>Protection</b>	IP67/ IP68
<b>Display</b>	Mobile Phone APP (RadarMe)
<b>Weight</b>	0.45kgs
<b>Sizes</b>	φ76mm×120mm
<b>Mounting hole thread</b>	M76X2, G1.5, G2

## 4.3 Application

### 4.3.1 Measured medium

In general, the dielectric constant of the measured medium is required to be greater than 4, so that it can have a good reflection cross section.

### 4.3.2 Ambient temperature of radar level sensor

The ambient temperature range of radar level sensor is: -20 °C ~ +70 °C. In areas with strong sunlight, it is recommended to install the instrument in a cool place or use a sunshade, which can not only avoid the excessive

temperature in the instrument caused by exposure to the sun, but also provide good ventilation and heat dissipation.

### 4. 3. 3 Protection grade

Waterproof and dust proof grade: IP67 / IP68.

## 5. Outline structure of radar level sensor

### 5. 1 Outline structure diagram

- Diagram 1

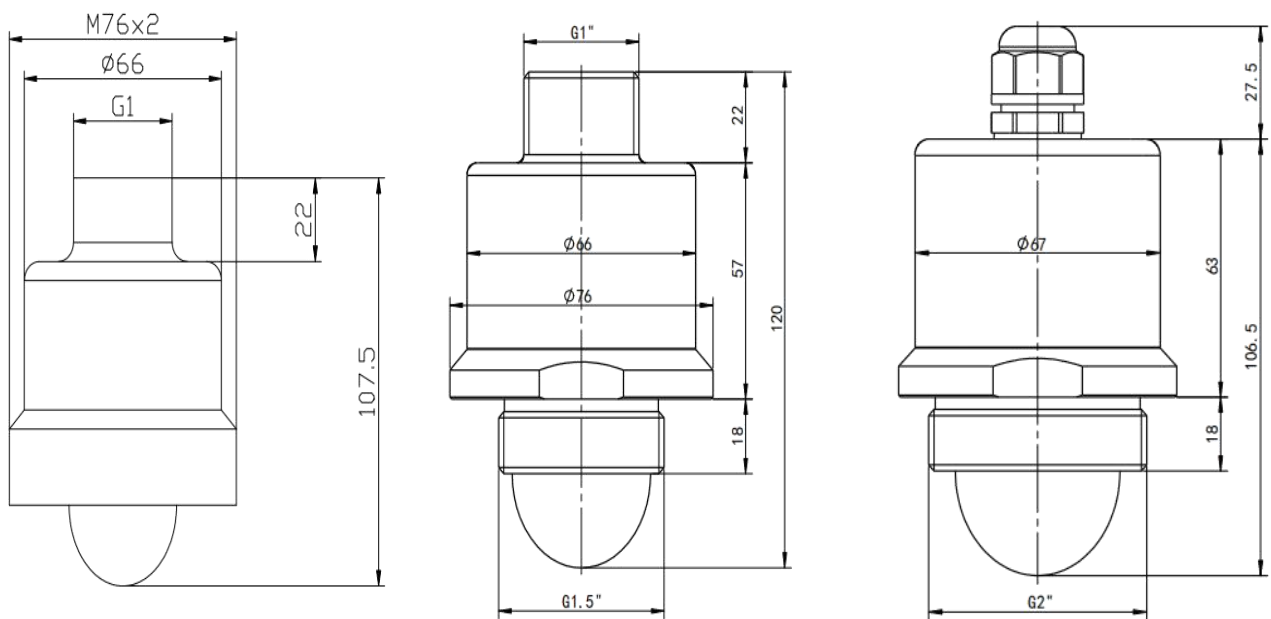

Thread Sizes: **M76X2**

**G1.5**

**G2**

P1. diagram for sizes

## 6. Terminal block of radar level sensor

The radar level sensor leads out two power lines, the red one is connected to the positive pole of the power supply, and the blue one is connected to the negative pole of the power supply.

- Interface description

Lead wire	Explain
Red (+)	DC24V Positive of power supply
Blue (-)	DC24V Negative of power supply
Yellow (+)	RS - 485 communication positive
Green (-)	RS - 485 communication negative

## 7. Wire connection

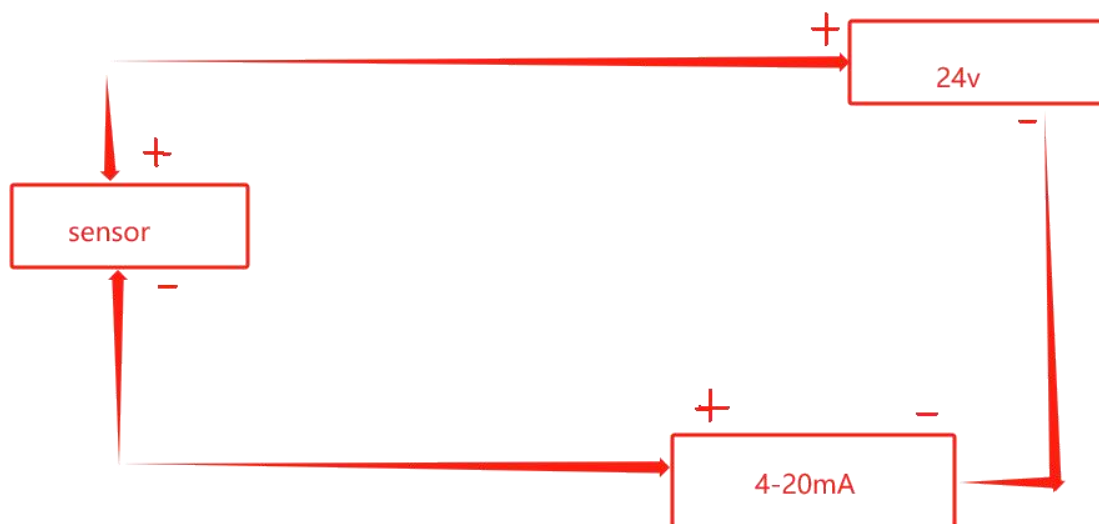



## 8. Modbus (RS485) connection

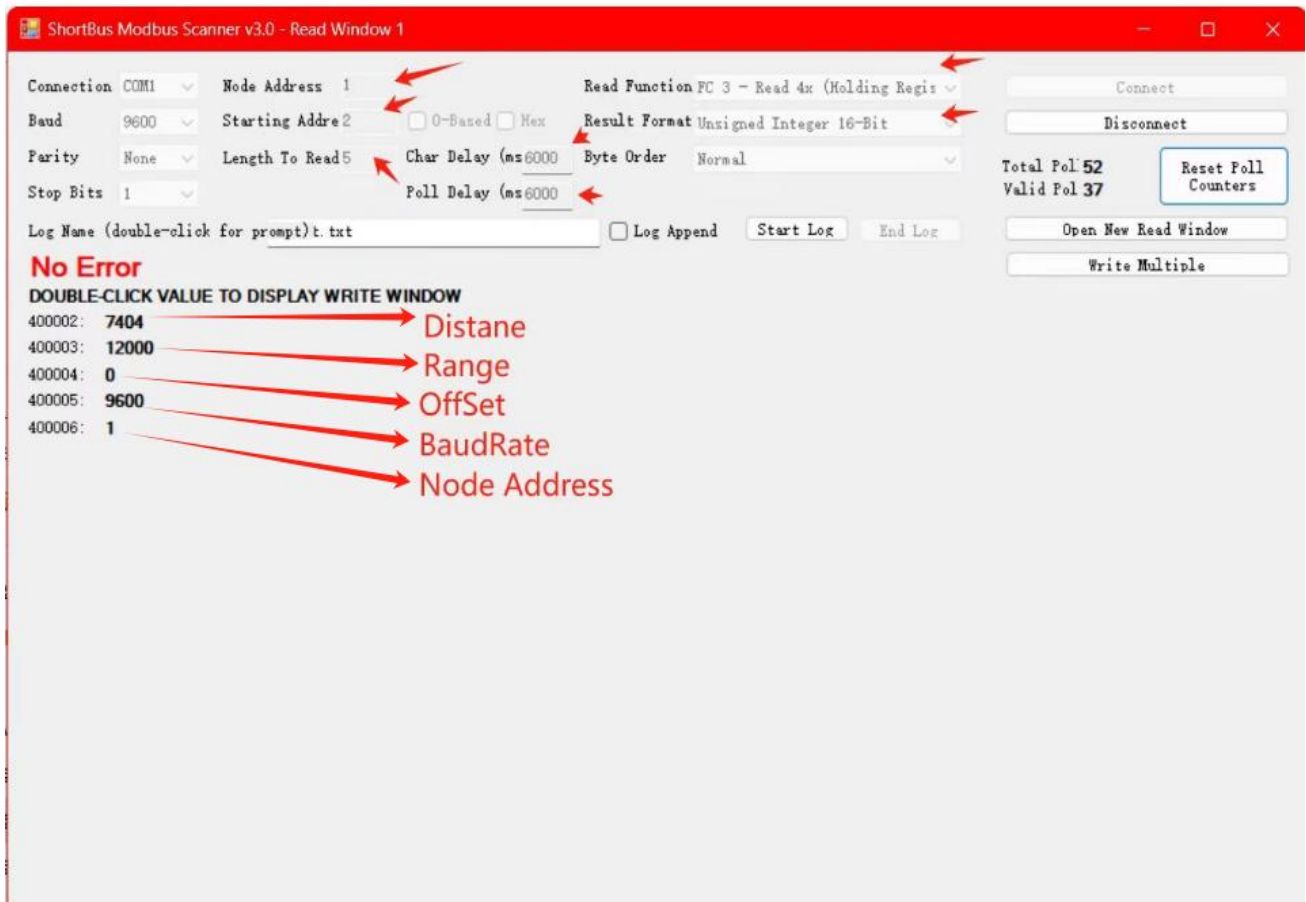

### 1: Read Paras, Use Command 0x03

Register List:

Address	Description	Data Type	Remark
0002H	Current Level	16 bit unsigned integer	Unit: mm
0003H	Measure Range	16 bit unsigned integer	Unit: mm
0004H	Base Offset	16 bit signed integer	Unit: mm
0005H	Baudrate	16 bit unsigned integer	Unit: bps
0006H	Device ID	16 bit unsigned integer	Value: 1-255

### 2: Write Paras, Use Command 0x10

Register List:

Address	Description	Data Type	Remark
0003H	Measure Range	16 bit unsigned integer	Unit: mm
0004H	Base Offset	16 bit signed integer	Unit: mm
0005H	Baudrate	16 bit unsigned integer	Unit: bps
0006H	Device ID	16 bit unsigned integer	Value: 1-255

## 9. Description of radar debugging parameters

Please download **RadarMe** on your mobile phone.

Android phone: Google Play.

iPhone: App Store.



Radar level sensor mobile app main interface.

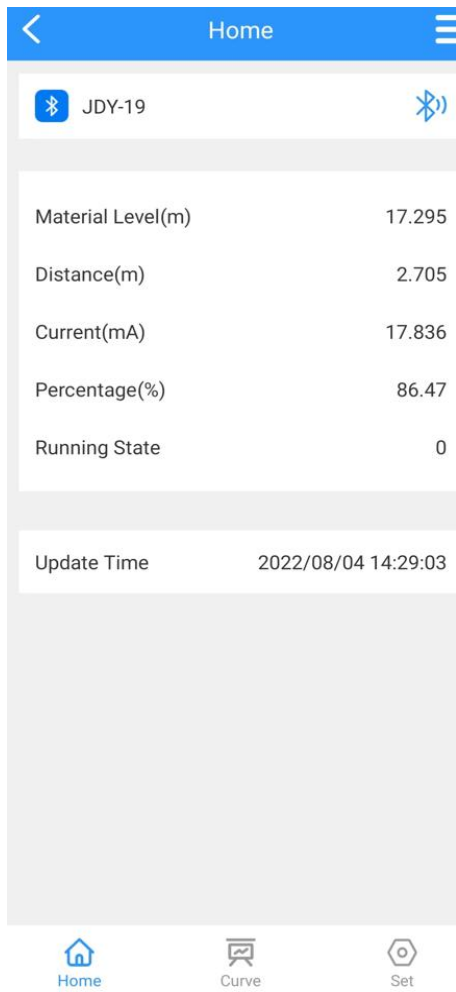

P2. RadarMe main interface

## 9.1 Waveform interface

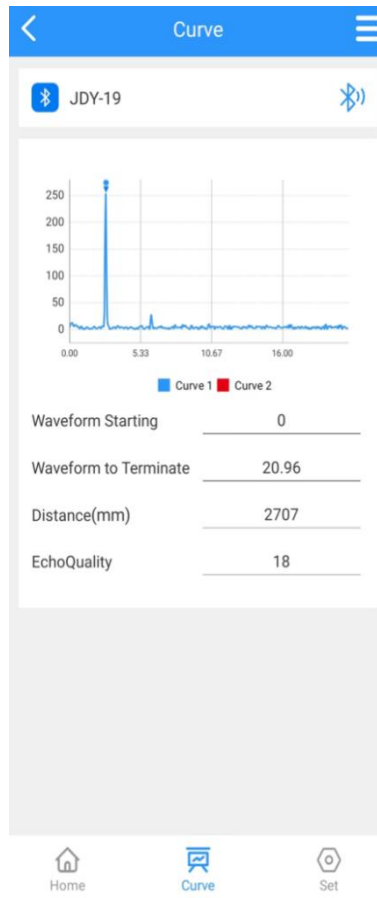

P3. waveform interface

## 9.2 Radar menu

### 9.2.1 User menu

Basic parameters	Measure range
	Migration/Offset
	4mA position

	20mA position
	Blind zone
	Damping time
	Device address
	Baud rate
	Backups
	Restore

### 9. 2. 2 Setting range and definition of basic parameters

- Basic settings:

**Range**(500~50000)mm: It depends on the working condition; Indicates the longest distance that the level sensor can measure.

**Migration**(-9999~9999)mm: It depends on the specific working conditions.

**4mA Position:** 4mA Level corresponding to current output, Unit mm

**20mA Position:** 20mA Level corresponding to current output, Unit mm

**Blind zone:** The range is 200mm to the measuring range, which is set according to the specific working conditions.

**Display type:** Level value / space distance value.

**Damping time:** In order to improve the stability of the measured output value, a larger [damping time] can be set to achieve the stability of the measured value and increase the anti-interference ability. For example, when the damping time is 10, the measured object level changes step at

time  $t$ , and the measured output value follows the actual position of the measured object after 10 seconds.

**Device address:** During RS-485 communication, the slave address is the local address (value range: 1-99, default value: 1).

**Baud rate:** The baud rate of this device during RS-485 communication is 9600 by default.

- Backup user parameters:

After the working parameters are backed up, if you forget the original working parameters after manually modifying the parameters, you can "restore" them in the basic settings.

- Restore user parameters:

Used to restore the backed up user parameters.

## 10. Radar installation and commissioning

### 10.1 Preparations before installation

- Understand the installation location, structure, measuring range.
- Required tools: DC-24V power supply, etc.

After the tools are ready, unpack the products and check the packing list to determine whether the materials are complete.

### 10.2 Selection of radar installation position

Avoid installing the instrument in the center or close to the edge of the

container, otherwise it is likely to produce wrong readings.

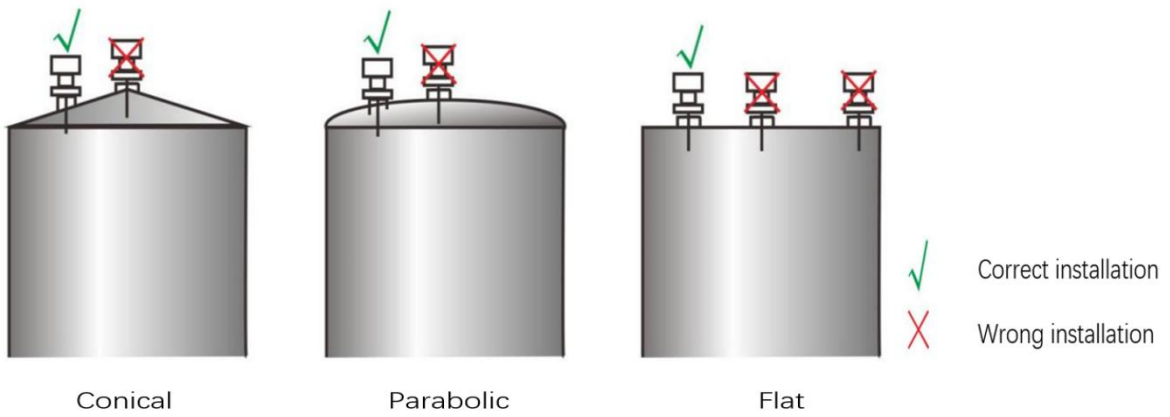
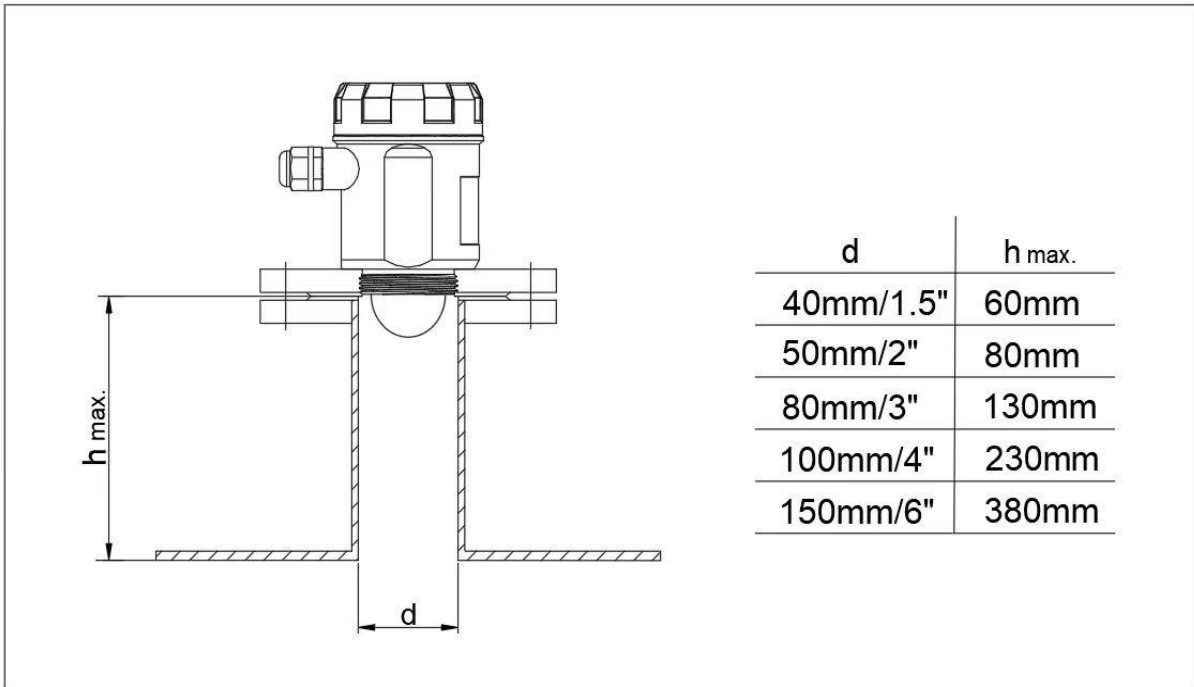

P4. installation position

- Avoid false echo diagram

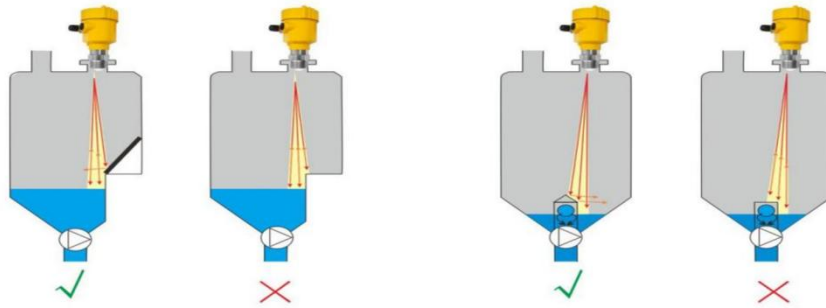

Avoid false wave examples

P5. False echo

- Treatment of stairs and grille tanks

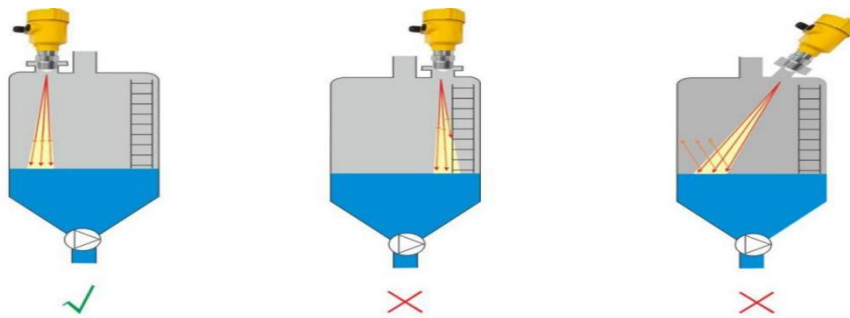

Treatment of stairs and grille tanks

P6. Treatment of stairs and grille tanks diagram

- Wall hanging and grid container treatment

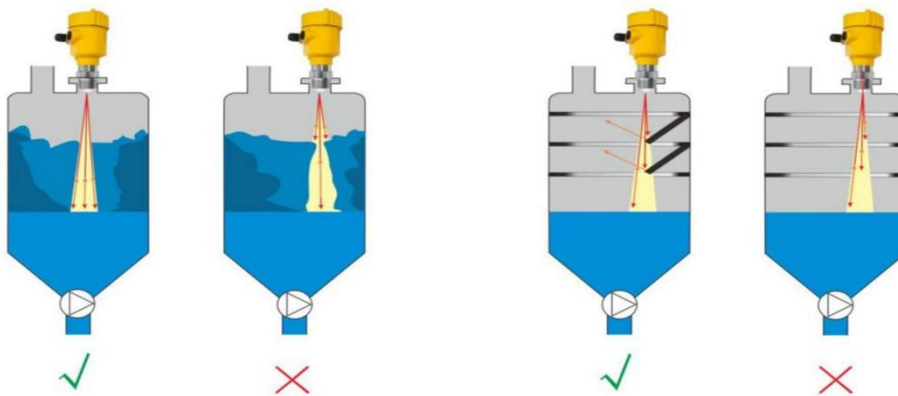

Treatment of wall hanging and grille tanks

P7. Wall hanging and Grid container



### 10.3 Software configuration description

- Instrument connection

Connect the power line to the DC 24V terminal of the instrument; Pay attention to the positive and negative poles, and do not connect them reversely.

- Set instrument parameters

Open the mobile app to display the device connection interface. As shown in the following figure:

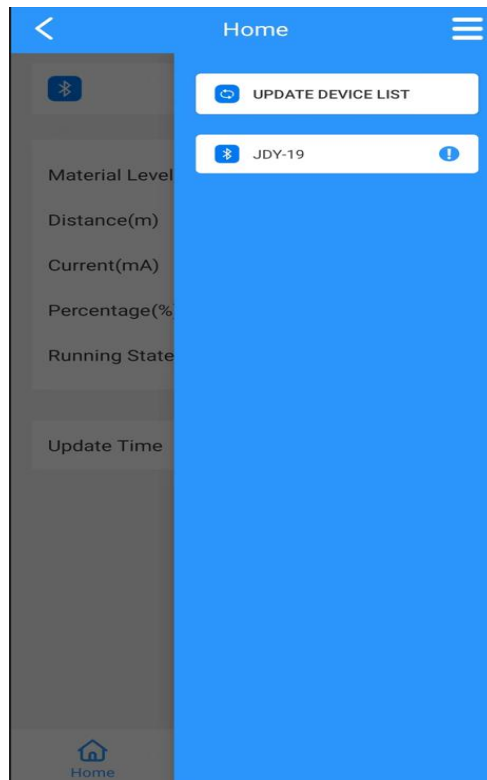

P8.

Directly click the device name to be set to enter the main interface, as shown in the following figure.

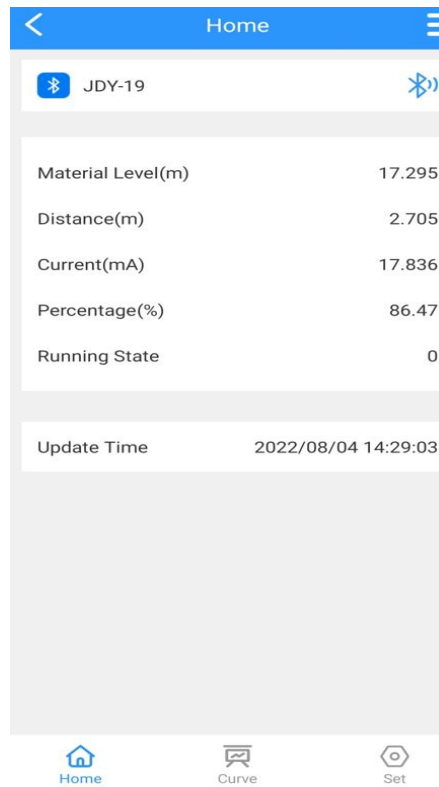

P9.

Click the "**curve**" or "**setting**" button at the bottom of the screen to enter the echo curve interface and parameter setting interface respectively. Click the "**setting**" button here to enter the parameter setting interface, as shown in the following figure.

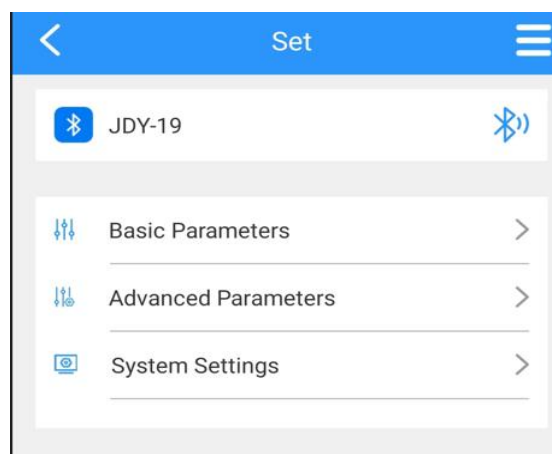

P10.

Click "**basic parameters**" to enter the basic setting interface. As shown in the following figure.

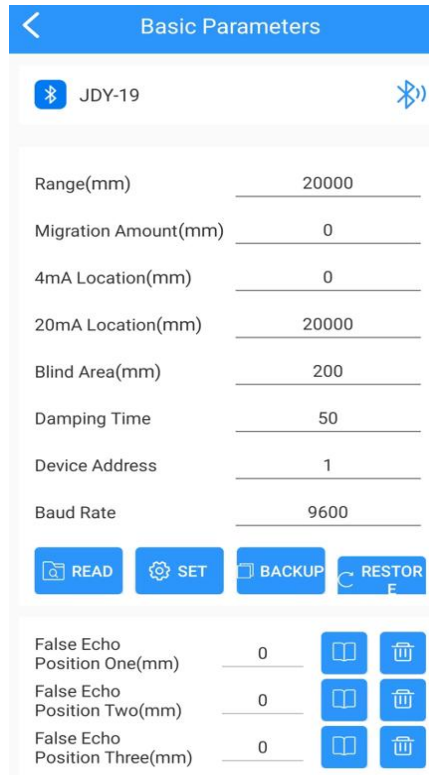

P11.

Set the **"range"** according to the working condition, directly click the following digital input box to modify, and the other parameters are modified in the same way. After the parameters are modified, you need to click the **"set"** button to set it before it takes effect. You can click the **"read"** button to refresh the parameters.

4mA position and 20mA position must be within the range. The relationship between 4mA position, 20mA position and range is shown in the following

figure:

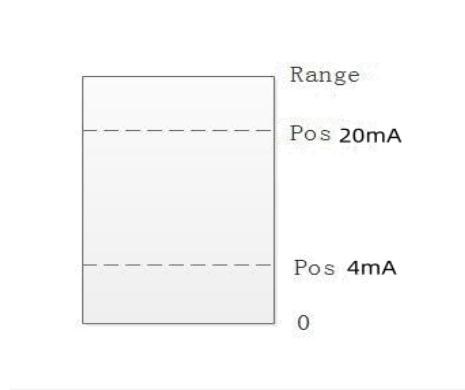

P12.

As shown in the figure, when the level is lower than 4mA, the main interface displays the level of 0, and when the level is higher than 20mA, the main interface displays the level value of 20mA.

## 11. Maintenance and repair

- Pay attention to keeping the radar sensor clean, and try to be waterproof, moisture-proof, corrosion-proof, and avoid being violently collided and hit by other objects.

- Avoid direct sunlight on the main body of the radar sensor, keep away from heat sources and pay attention to ventilation. If the ambient temperature exceeds the rated temperature, corresponding cooling protection measures should be taken.

- When the ambient temperature is too low, the instrument protection box or other protective devices can be used for antifreeze protection, and pay attention to keeping the radar dry.

- Radar sensor should be detected regularly. (the detection cycle is

determined by the user according to the specific situation).

## 12. Trouble Shooting

Trouble	Cause	Solution
No display	Power supply error	Check whether the DC 24V voltage and current meet the requirements.
	Wiring error	Check whether the wiring is correct.
Unstable indication	Too much fluctuation	Change the installation position of the radar or reduce the fluctuation of the object to be measured.
	Weak echo	Try angle calibration or rotate the radar installation position.
	Strong electromagnetic interference	Ground or shield the radar level sensor.

Error code:

E01: Liquid level not found

E02: Liquid level jump is too large

E04: Abnormal capacitor charging

E40: Screen communication failure

E08: Actual liquid level does not match 4-20mA position (high, low).

### **(SKE) Shaanxi ShengKe Electronic Technology Co., Ltd**

Tel: (86)029-88858601

Fax: 029-88858601

E-mail: [sales@skgauge.com](mailto:sales@skgauge.com)

Post code: 710075

Website: <https://www.skgauge.com/>

Address: Room 1911. Fazhan 25 Road, High-Tech Zone Xi'an, Shaanxi China.